

according to Kobel and Neberg<sup>7</sup> was treated with the resin exchange adsorbents and recovered as the amorphous calcium salt by precipitation with alcohol. Analysis of this hexosediphosphate before treatment with the ion exchange adsorbents showed only 70% purity, the chief contaminants being proteins and calcium phosphate. After purification by the aid of the resin exchange adsorbents the calcium salt of the fructose diphosphoric acid was obtained in pure condition. *Anal.* Calcd. for  $C_6H_{10}O_8(PO_3Ca)_2$ : P, 14.9; Ca, 19.2. Found: P, 15.3; Ca, 19.4.

Crude fructose-6-monophosphate (75% purity) was similarly treated with the resin exchange adsorbents and the ester recovered as the barium salt. *Anal.* Calcd. for  $C_6H_{11}O_6(PO_3Ba)$ : P, 7.8; fructose, 45.5. Found: P, 8.0; fructose, 45.5.

The authors wish to thank Drs. J. R. Matchett, R. R. Le Gault and J. F. Carson for their interest and valuable suggestions.

### Summary

A method for preparation of dipotassium glucose-1-phosphate dihydrate is described. The glucose-1-phosphate is obtained by digesting a starch with crude potato phosphorylase in the presence of inorganic phosphate and the purification of the ester is accomplished by using ion exchange adsorbents.

BERKELEY, CALIFORNIA

RECEIVED JANUARY 10, 1944

[CONTRIBUTION FROM THE DEPARTMENT OF BIOCHEMISTRY AND PHARMACOLOGY AND THE DEPARTMENT OF RADIOLOGY, SCHOOL OF MEDICINE AND DENTISTRY, THE UNIVERSITY OF ROCHESTER]

## The Autoxidation of $\beta$ -Eleostearic Acid. The Application of the Spectrophotometer to the Study of the Course and the Kinetics of the Reaction<sup>1,2</sup>

BY RALPH W. BRAUER<sup>3</sup> AND LUVILLE T. STEADMAN

The course and mechanism of the reactions between unsaturated fatty acids and molecular oxygen have remained obscure in spite of a vast amount of careful investigation. The solution of this important problem has been held up by a dilemma which the conventional approach has been unable to evade: Either the autoxidation takes a complicated destructive course, with the formation of numerous secondary products, or there are several centers within the molecule capable of undergoing reaction. In either case the methods hitherto employed measure a number of simultaneously occurring reactions which cannot be disentangled for theoretical studies.

Of the known fatty acids, those which contain a conjugated system of unsaturation show the least breakdown and the most clearly defined oxygen uptake. Due to their conjugated double bonds, these compounds all show strong absorption of light in the middle or remote ultraviolet region. This property permits the determination, impracticable by other methods, of a particular grouping throughout the course of the autoxidation reaction. Thus, in spite of the fact that more than one center in these molecules is capable of absorbing oxygen, it becomes possible to dissociate the various reactions from one another to some degree.

The work reported in this paper has been performed upon  $\beta$ -eleostearic acid, an octadecatrienoic acid of structure

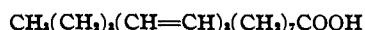

(1) Submitted by Ralph W. Brauer in partial fulfillment of the requirements for the degree of Doctor of Philosophy to the Division of Graduate Studies of the University of Rochester.

(2) Read in part before the Division of Biological Chemistry at the 104th meeting of the American Chemical Society, Detroit, April, 1943.

(3) Present address: Distillation Products, Inc., Rochester, N. Y.

which is readily obtained in a state of high purity from tung oil. The autoxidation of this material was followed by spectrophotometric means and by simultaneous oxygen uptake measurements.

In order to attain a satisfactory degree of accuracy and reproducibility, it was deemed desirable to carry out the reactions in liquid solutions in an inert solvent. This required the development of a special technique for the oxygen uptake measurements, which will be described below in some detail, not only as an integral part of the spectrographic studies, but also because the procedure permits the investigation of the relation between the concentration of autoxidizable substrate and the rate of autoxidation. In the opinion of the authors such studies are of vital importance to the further elucidation of the mechanism of autoxidation of ethylenic systems.

### Experimental

**$\beta$ -Eleostearic Acid.**—Sulfur isomerized tung oil<sup>4</sup> was saponified according to the method of Dann, *et al.*,<sup>5</sup> and the non-saponifiable matter was extracted with ether from the alkaline mixture diluted 1:1 with water. The aqueous layer was separated and acidified after heating to about 90°. The liberated fatty acids were washed repeatedly with hot water, and finally solidified by the addition of ice water, and were then separated by filtration.  $\beta$ -Eleostearic acid was isolated from the mixed fatty acids by crystallization, once from methyl alcohol and three times from petroleum ether (b. p. 40–60°) at 0°.

The  $\beta$ -eleostearic acid thus obtained consisted of white platelets of m. p. 71.5–71.8°. The entire isolation was performed under nitrogen. The final product was stored in the dark in nitrogen-flushed containers, kept evacuated to less than 1 mm. of mercury.

***n*-Amyl Acetate.**—The commercial product (Eastman Kodak Co., c. p. grade) was purified by two different pro-

(4) The authors hereby acknowledge the kindness of Mr. C. F. Goodyear, President of the Bogalusa Tung Oil Corp., Bogalusa, La., in providing the oil employed in this work.

(5) Dann, Moore, Booth and Kon, *Biochem. J.*, **29**, 133 (1935).

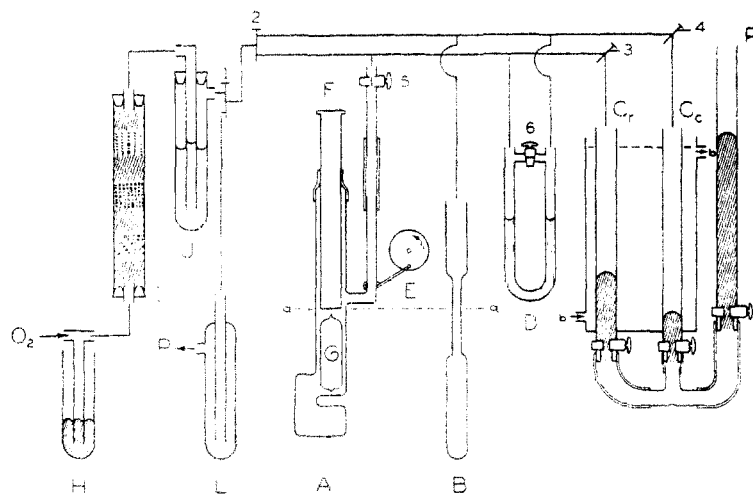

Fig. 1.—Apparatus for the study of the oxygen uptake of solutions of fatty acids.

cedures, namely, that of Likhtman<sup>6</sup> and that recommended by Weissberger and Proskauer.<sup>7</sup> The physical constants of samples prepared by either procedure were identical and indicated the presence of some lower esters in the product. Neither sample showed any oxygen uptake when shaken for twenty-four hours at 64.5° under 1 atmosphere of oxygen in the dark.

**Preparation of Solutions.**—In all, five solutions were employed in the experiments here reported. The concentrations are shown in Table I. These solutions were

TABLE I

Solution no.	1	2	3	4	5
Concn. in g. $\beta$ -eleostearic acid per 10 cc. soln.	0.204	0.315	0.397	0.890	1.490

made up by weight under nitrogen in 5-g. lots and were freed of air by passing a stream of solvent-saturated nitrogen through the liquid for five minutes. Aliquots of 0.2–0.5 g. were weighed under nitrogen into thin-walled ampules, which were then cooled to  $-80^\circ$ , evacuated and sealed. The finished ampules were kept in a dark vacuum desiccator, evacuated to below 1 mm.

**Apparatus and Procedure.**—The apparatus employed in these experiments consisted essentially of the following parts (see Fig. 1): the reaction cell A attached to the shaking eccentric E and connected to the manometer D and the gas buret  $C_r$ ; the compensating cell B attached to the other side of the manometer D and to the gas buret  $C_c$ ; the gas and vacuum train, consisting of the mercury trap H, the drying tower I, the solvent saturating tube J and the dry-ice trap L placed before the vacuum pump P; the stopcock manifold 1, 2, 3, 4, 5, 6, which permitted the connection of the various parts of the system with one another and the atmosphere. Cells A and B were kept in the water thermostat a-a which was maintained at  $64.5 \pm 0.2^\circ$ . The gas burets  $C_r$  and  $C_c$  were placed in the circulating water jacket b-b thermostated at  $28.0 \pm 0.3^\circ$ . A shaking rate of 40 cycles per minute was found to be well above the critical rate of shaking and was employed throughout.

The apparatus was operated as follows: Stopcock 6 was opened, thus putting the manometer D out of operation. The glass rod F was removed from cell A and the solution to be tested was introduced in ampule G. A was then closed by replacing F into its rubber collar, and

the shaking mechanism was started. The entire apparatus was next evacuated and tested for leaks. After the system had been made completely gas-tight, dry oxygen, saturated with *n*-amyl acetate vapor, was admitted through H, I, J into all parts of the apparatus. This procedure of alternately evacuating and filling with oxygen was repeated three times and finally the oxygen pressure within the apparatus was brought to 10–15 mm. of mercury above atmospheric pressure. After fifteen minutes the apparatus had reached temperature equilibrium. The reaction was then started by crushing ampule G with the rod F. Gas pressure within the apparatus was adjusted to atmospheric pressure by momentarily opening stopcocks 3 and 4 to the outside, and finally the manometer arms were separated by closing 6. Oxygen uptake was measured directly by introducing mercury from the reservoir R into the gas buret so as to maintain a constant oxygen pressure differential between A and B. The geometry of the apparatus

was such that distillation of solvent from A into  $C_r$  did not take place to any detectable amount under the conditions of the experiments. All volume changes employed in the calculations are uncorrected for the partial pressure of the solvent since suitable data are not available in the literature. When such data become available a downward correction of all oxygen values reported below will have to be made which will probably not exceed 2–3%.

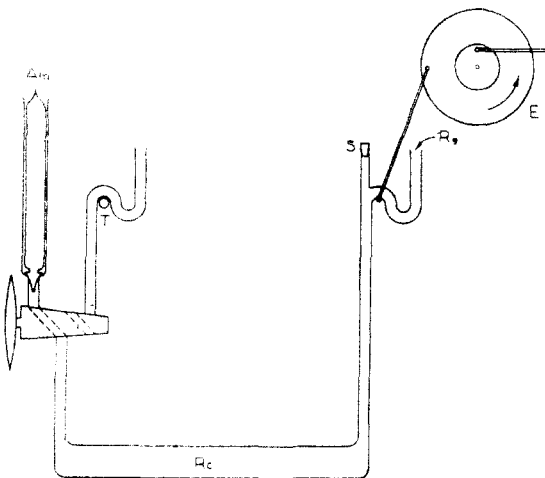

Fig. 2.—Oxidation cell for the spectrographic studies.

For the spectrographic experiments the cell shown in Fig. 2 was connected to the shaking eccentric and simultaneous oxygen uptake and spectrophotometric determinations were performed. The sample was introduced into the spectrographic cell by cracking both ends of the ampule Am. The cell  $R_g$  was next flushed with oxygen and connected to the gas reservoir  $R_g$  which was kept filled with oxygen at atmospheric pressure. From time to time samples for spectrographic analysis were withdrawn from the cell through the stud S. Such samples were weighed and diluted with a calculated amount of ether to a concentration of 1.84 mg. of  $\beta$ -eleostearic acid per liter of ether for the initial samples; for the later samples the concentrations were adjusted so that the density at 2685 Å. was between 1.5 and 2.0. The spectrographic examination was performed by means of a medium size Bausch and Lomb quartz spectrograph using a rotating sector spectrophotometer with an iron spark as light source.

(6) Likhtman, USSR Patent 52,647; *cf. C. A.*, **34**, 5468 (1940).

(7) Weissberger and Proskauer, "Organic Solvents," Oxford University Press, 1935.

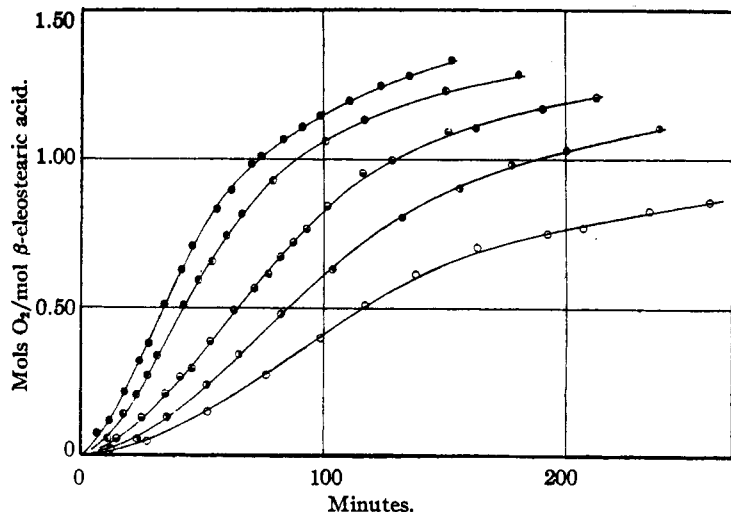

Fig. 3.—The oxygen uptake of solutions of  $\beta$ -eleostearic acid in *n*-amyl acetate: ○, solution no. 1; ◐, solution no. 2; ◑, solution no. 3; ◒, solution no. 4; ●, solution no. 5 (cf. Table I).

### Results and Discussion

Figure 3 shows the oxygen uptake of different concentrations of solutions of  $\beta$ -eleostearic acid in *n*-amyl acetate as a function of time.

In all cases induction periods of from twenty to forty minutes were observed. These, however, were found to be irreproducible even with duplicate samples of the same solutions.<sup>8</sup> The variations observed in the induction periods apparently were not due to impurities present in the solvents, since no differences could be observed between the solvent purified by the two procedures.<sup>6,7</sup> Neither can the blame be laid upon impurities of the acid employed, since all samples were prepared from the same batch of material. The oxygen tension was substantially the same in any duplicate experiments; the extremes of the variation of total pressure of the entire series of experiments were 755.5 and 729.8 mm. of mercury, respectively; hence, this factor can hardly be responsible for the results obtained. A plausible explanation might be found in the persistence of minute traces of dissolved oxygen in the solvent in spite of the precautions taken.

But for their induction periods, duplicate oxygen uptake curves were found to be superimposable within an accuracy of  $\pm 1-2\%$ . The induction periods shown in Fig. 3 were arbitrarily chosen to permit convenient representation.

Several samples were studied for twenty-four to thirty-six hours. In all cases it was found that the uptake of oxygen became extremely small after 2 mols of oxygen per mol of  $\beta$ -eleostearic acid had been absorbed. These observations agree with those of Myers, Kass and Burr,<sup>8</sup> who studied the autoxidation of the acid spread upon filter paper at 40° and with the results of Miller and Claxton,<sup>9</sup>

(8) Myers, Kass and Burr, *Oil and Soap*, **18**, 107 (1941).

(9) Miller and Claxton, *Ind. Eng. Chem.*, **20**, 43 (1928).

who worked with the molten acid at 80°. The agreement of these various experiments suggests that the main reaction is terminated when 2 mols of oxygen have been taken up per mol of  $\beta$ -eleostearic acid, and that any further oxygen absorption represents a side reaction, possibly of a degradative type.

The final product of the autoxidation has been isolated by the dilution of the completely oxidized solutions with petroleum ether. This procedure precipitates the oxidized material, a dark brown, viscous, non-volatile oil. Analysis<sup>10</sup> showed a composition  $C_{86}H_{58.8}O_{12.2}$ , a neutral equivalent of 312.4 and a molecular weight of about 600 (ebullioscopic determination in acetone). These properties would agree closely with those expected for a dimer of  $\beta$ -eleostearic acid, formed with the uptake of 2 mols of oxygen

per mol of acid and without the participation of the carboxyl groups:  $C_{86}H_{58.8}O_{12}$ , neutral equivalent 315, molecular weight 630. All attempts to crystallize this material have failed so far, and it is suggested that several isomers are present which differ in the relative orientation of the chains (head-to-head or head-to-tail), the sites of mutual attachment and possibly in geometric configuration.

The rate of oxygen uptake in each experiment increased from 0 to a maximum after the absorption of 0.3 to 0.5 mol of oxygen per mol of  $\beta$ -eleostearic acid, and thereafter decreased slowly, to reach 0 when the limiting amount of oxygen had been consumed (see, *e. g.*, Fig. 7). The re-

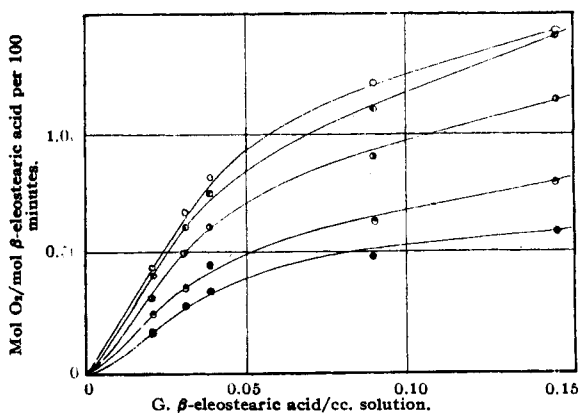

Fig. 4.—The rate of oxygen uptake of solutions of  $\beta$ -eleostearic acid in *n*-amyl acetate as a function of the initial concentration: ●, after the absorption of 0.025; ◐, of 0.050; ◑, of 0.100; ◒, of 0.200; and ○, of 0.300 mol of oxygen per mol of  $\beta$ -eleostearic acid.

(10) The authors are indebted to Mr. H. Baumann of the Department of Chemistry of this University for the combustion analyses performed in connection with this work.

lation between initial concentration and oxygen uptake rates for various stages of the reaction is represented in Fig. 4. Henderson and Young<sup>11</sup> working with oleic acid dissolved in stearic acid at 70° reported a relation

$$\text{Rate of oxygen uptake} = A + B \times (\text{initial concentration of oleic acid})$$

where  $A$  and  $B$  are constants. It will be observed that a similar equation might have been derived for  $\beta$ -eleostearic acid by an observer who would employ a concentration greater than 0.05 g. of  $\beta$ -eleostearic acid per cc. of solution as the basis of his considerations.

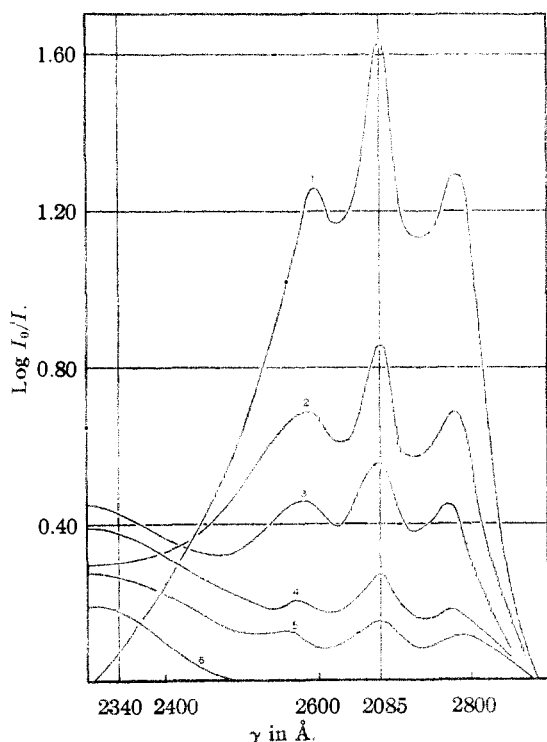

Fig. 5.—The spectroscopic changes during the autoxidation of  $\beta$ -eleostearic acid in solution in  $n$ -amyl acetate (solution no. 2, Table I). The numbers denote the order in which the samples were withdrawn.

The outstanding characteristic of the absorption spectrum of  $\beta$ -eleostearic acid is the very strong band around 2685 Å. as shown by curve 1, Fig. 5. On autoxidation this characteristic band decreases in intensity and finally disappears. Simultaneously, a new absorption band appears on the short wave length side of 2500 Å., reaches a maximum intensity and then slowly disappears. Unfortunately, the spectrograph employed does not permit measurements below 2330 Å., so that only one side of the new band can be observed. This restriction makes it impossible to definitely identify the new band as due to a particular chromophore. Under the conditions of these experiments, two groupings might plausibly give

(11) Henderson and Young, *J. Phys. Chem.*, **46**, 670 (1942).

rise to this new absorption band, namely, a peroxide grouping<sup>12</sup> or a conjugated diene system.<sup>13</sup> The intensity of the band observed, its sharp slope and certain quantitative considerations to be presented below seem to favor the view that this band is due to two conjugated double bonds. The situation is further complicated by the appearance of a relatively weak generalized absorption rising toward the ultraviolet, which is responsible for the yellowish to brown color of the final products. This color may be related to the yellow discoloration of autoxidized tung oil. A preliminary investigation of this effect has shown that yellowing tung oil can be reversibly bleached by diffuse daylight. The relation of these colors to the other absorption bands observed and the nature of the chromophores involved is as yet obscure.

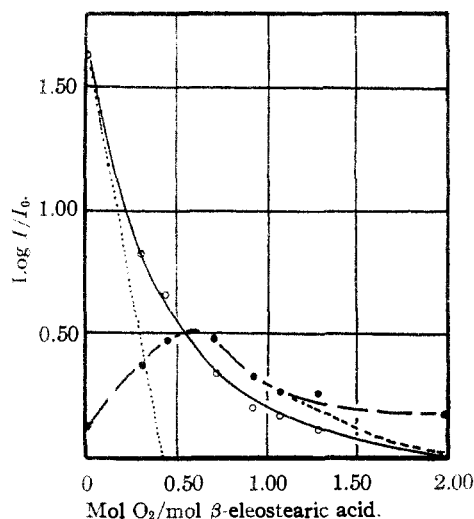

Fig. 6.—The extinction coefficients of autoxidizing  $\beta$ -eleostearic acid as a function of oxygen taken up: O,  $\log I_0/I$  at 2685 Å.; ●,  $\log I_0/I$  at 2340 Å.; —, calculated from equation 1; - - - - - , late course of diene curve as predicted from reactions A and B.

Figure 6 shows the relation between the amount of oxygen absorbed and the extinction coefficient of the autoxidizing solution at 2685 and at 2340 Å., respectively. The relation between the extinction coefficient of the triene band and the amount of oxygen taken up is given by the empirical expression:

$$K_{3\Delta t} = K_{3\Delta\infty} \frac{O_{2\infty} - O_{2t}}{(1.265 O_{2t} + \sqrt{O_{2\infty}})^2}$$

where  $O_{2\infty}$  and  $O_{2t}$  represent the amount of oxygen taken up at infinite time and at time  $t$ , respectively, and where  $K_{3\Delta\infty}$  and  $K_{3\Delta t}$  represent the extinction coefficient at 2680 Å. at zero time and at time  $t$ , respectively. In view of what has been said

(12) E. Rieche, "Alkylperoxyde und Ozonide," T. Steinkopff Leipzig, 1931.

(13) D. T. Mowry, W. R. Borde and J. B. Brown, *J. Biol. Chem.*, **142**, 671 (1942); J. H. Mitchell, Jr., H. R. Kraybill and F. D. Zschelle, *Ind. Eng. Chem. Anal. Ed.*, **15**, 2 (1943).

above,  $O_{2\infty}$  is equal to 2.0 mols of oxygen per mol of  $\beta$ -eleostearic acid. From this expression it is possible to compute the rate of triene destruction at any moment of the reaction from the oxygen uptake curve and relatively few spectrographic data. The following relation is obtained

$$(1) \quad \frac{d}{dt} K_{3\Delta t} = \frac{\partial K_{3\Delta t}}{\partial O_2} \frac{dO_2}{dt} = \frac{dO_3}{dt} \times K_{3\Delta 0} \times \frac{1.265(O_{2t} - 2O_{2\infty}) - \sqrt{O_{2\infty}}}{(1.265 O_{2t} + \sqrt{O_{2\infty}})^2}$$

Figure 7 shows the rate of triene destruction computed by means of this equation as a function of the residual intact triene (curve a). For comparison the rate of reaction as measured by oxygen uptake is plotted as curve b into the same figure. The relative position of the maxima of the two curves is an expression of the fact that groupings other than the triene system take an increasingly important part in the absorption of oxygen as the reaction progresses.

The marked asymmetry of curve a is of theoretical interest. Either a simple autocatalytic mechanism or a mechanism involving an autocatalytic chain reaction would lead to the prediction of a symmetrical shape for this curve. The asymmetry of curve a, Fig. 7, is therefore indicative of one of two possibilities: either a catalyst which is formed in the first stages of the reaction is destroyed in later phases, or an inhibitor substance gradually accumulates during the course of the reaction. Which of these possibilities is the correct one cannot be determined on the basis of available data.

The data presented in Fig. 6 also give some indication of the fate of the absorbed oxygen. Inspection of the triene decay curve will reveal the fact that the intercept with the  $O_2$  axis of the tangent drawn to this curve at the value  $O_2 = 0$ , yields directly the value of the ratio ( $O_2$  taken up)/(triene destroyed) at the start of the reaction. Calculation shows this value to be equal to 0.44. Thus, a little less than  $1/2$  mol of oxygen suffices initially to destroy 1 mol of triene system. Present evidence indicates that the uptake of oxygen by unchanged molecules does not involve the initial rupture of the strong O-O bond. The results here obtained can be explained in terms of either of two hypotheses: (A) the peroxidation is succeeded by a very rapid decomposition reaction involving the peroxidized molecule and one intact molecule; or (B) the initial peroxidation may lead either directly or in a rapid secondary reaction to the formation of dimeric products with the formation of additional C-C and C-O bonds. These products may or may not be peroxidic. The fact that low molecular weight decomposition products are not observed in the course of the autoxidation of  $\beta$ -eleostearic acid makes the first of these possibilities improbable, while the assumption that dimerization is an essential part of the reaction between the triene and molecular oxygen is

supported by the appearance of dimers of the original acid as the major product of the reaction. The somewhat low value obtained for the initial oxygen to triene ratio (0.44 instead of 0.50) may be due to a reaction caused by the peroxide and which leads to the formation of polymers of the unoxidized acid.<sup>14</sup>

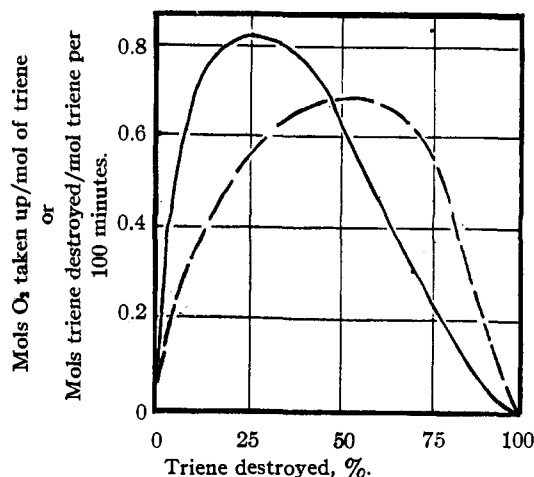
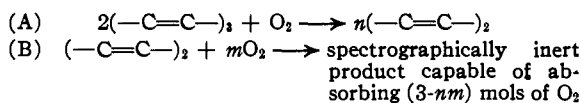

Fig. 7.—Rate of autoxidation as measured by oxygen uptake or by triene destruction: (a) ———, triene destruction; (b) - - - - -, oxygen uptake.

The oxygen-triene curve very soon deviates from the tangent which would represent the course of the reaction if only the step described above took place. A closer approach to the observed oxygen uptake can be achieved if it be assumed that the absorption at 2340 Å. is due to a conjugated diene which is formed directly from the triene and which in turn is capable of absorbing oxygen. The sequence of the reactions which would represent this hypothesis is



These formulas permit the calculation of the relation between the amount of oxygen taken up and the diene and triene extinction coefficients after various periods of reaction. The relation obtained is

$$(2) \quad O_2 = \frac{K_{3\Delta 0} - K_{3\Delta t}}{2K_{3\Delta 0}} (1 + mn) - m \frac{K_{2\Delta t} \epsilon_{3\Delta}}{K_{3\Delta 0} \epsilon_{2\Delta}}$$

where  $\epsilon_{3\Delta}$  and  $\epsilon_{2\Delta}$  designate the specific extinction coefficients of the triene and the diene, respectively. The ratio  $\epsilon_{3\Delta}/\epsilon_{2\Delta}$  has been determined by extrapolation from the experimental data. If  $n$  is assumed to be  $1/2$ , or 1, or 2, then  $\epsilon_{3\Delta}/\epsilon_{2\Delta}$  equals 2, or 1, or  $1/2$ , respectively. From the authors' data for  $\beta$ -eleostearic acid and from those of Van der Hulst<sup>15</sup> for 9,11-linoleic acid, this ratio can be computed and is found to be 1.5, thus eliminating

(14) Tatimori, *J. Soc. Chem. Ind., Japan*, **44**, suppl. 8 (1941).

(15) Van der Hulst, *Rec. trav. chim.*, **54**, 639 (1935).

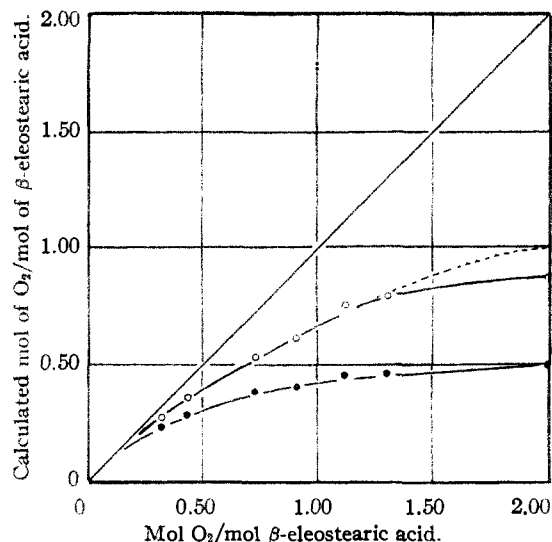

Fig. 8.—The absorption of oxygen by eleostearic acid: (a) ———, observed; (b) O—O, calculated from formula 2; (c) ●—●, calculated according to reaction A alone.

$n = 2$ . Further calculation shows that only the case  $n = 1, m = 1$  yields satisfactory results. The curve calculated on this basis is shown as curve b, Fig. 8. For comparison, the curve computed on the assumption that the oxygen uptake value  $= \frac{1}{2} \times$  (mols of triene destroyed) is shown in the same figure as curve c and the experimental values are indicated by the straight line a. The course of curve b deviates in its later part from that expected on the basis of the proposed scheme of reactions as indicated by the dotted line on the graph. This deviation might be due to the generalized light absorption mentioned earlier in this paper and which becomes more prominent as the reaction progresses. The difference between the value of  $\epsilon_{3\Delta}/\epsilon_{2\Delta}$  as observed in these experiments and as calculated from the studies on pure compounds is hardly surprising in view of the fact that the hypothetical diene certainly must possess a structure differing widely from that of the straight chain fatty acid investigated by Van der Hulst.

The results reported in this paper permit no more than a tentative description of the autoxidation of  $\beta$ -eleostearic acid. Further progress will depend largely upon an elucidation of the structure of the several compounds<sup>16</sup> formed as intermediate and final products of the reaction. Some preliminary work has been performed in this connection and has indicated marked differences in the stability of differently combined oxygen. In the dimeric acid already described, all but  $\frac{1}{2}$  mol of oxygen per mol of  $\beta$ -eleostearic acid is un-

(16) It would seem inadvisable, therefore, to make use of structural formulas in this paper: such formulas at the best could only represent one of a very considerable number of possible reaction courses, and their use would thus obscure rather than clarify the results actually obtained.

stable and can be removed by boiling for one hour with 2% aqueous potassium hydroxide. The product obtained from such treatment is still a dibasic dimer of  $\beta$ -eleostearic acid of composition  $C_{96}H_{168.0}O_{5.92}^{10}$  (formula for 2 mols  $\beta$ -eleostearic acid +  $\frac{1}{2}$  mol  $O_2 = C_{96}H_{160}O_6$ ). In view of the fact that  $\frac{1}{2}$  mol of oxygen initially accounts for the destruction of one triene system, this observation may hold a valuable clue.

**Acknowledgment.**—Ralph W. Brauer wishes to acknowledge gratefully the constant friendly advice and encouragement of Dr. Harold C. Hodge. He also desires to express his gratitude toward Professor W. R. Bloor for his friendly attitude which has materially aided in the completion of this research.

### Summary

1. A method has been described for the study of the autoxidation of fatty acids in liquid solution by oxygen uptake measurements and by the simultaneous determination of the absorption spectra of the autoxidizing solutions.

2. Curves showing the relation between the rate of oxygen uptake of  $\beta$ -eleostearic acid and the initial concentration of the substrate have been presented.

3. From the spectrographic changes observed in autoxidizing solutions of  $\beta$ -eleostearic acid, it has been suggested that during the reaction a conjugated diene is formed which in turn undergoes autoxidation.

4. A method has been described which permits the computation of the rate of triene destruction employing (a) the oxygen uptake curves and (b) the relation between absorbed oxygen and residual intact triene groups.

5. In order to destroy 1 mol of  $\beta$ -eleostearic acid, slightly less than one-half mol of oxygen is required initially. Consequently, it has been assumed (a) that the initial uptake of oxygen by  $\beta$ -eleostearic acid results in a dimerization involving the formation of some carbon to carbon bonds and (b) that a parasitic polymerization reaction is induced by the peroxides formed in the course of the reaction. The formation of dimeric products in the reaction has been verified by molecular weight determinations.

6. The amount of oxygen taken up can be computed approximately for the early stages of the reaction from the extinction coefficients of the diene and the triene bands if the following sequence of reactions is assumed

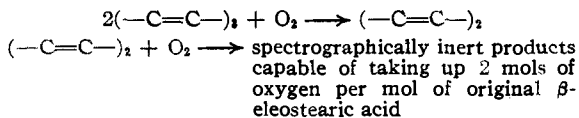

7. The rate of oxygen absorption by  $\beta$ -eleostearic acid becomes insignificant after an uptake of 2 mols of oxygen per mol of  $\beta$ -eleostearic acid.

This amount of oxygen can be recovered in a dibasic acid which is probably a dimer of the original acid. Three-fourths of the absorbed

oxygen in this product is removed by treatment with alkali.

ROCHESTER, N. Y.

RECEIVED SEPTEMBER 28, 1943

[CONTRIBUTION FROM KENT CHEMICAL LABORATORY, THE UNIVERSITY OF CHICAGO]

## Cross-Sectional Areas of Molecules Adsorbed on Solid Surfaces<sup>1a</sup>

By H. K. LIVINGSTON<sup>1b</sup>

The data relating to the cross-sectional areas of molecules in insoluble monolayers adsorbed on water are quite extensive. Adam<sup>2</sup> has listed limiting area values for 26 different classes of molecules. Recently, an increasing number of adsorption studies for gases and vapors adsorbed on solid surfaces of *known area* have been reported.<sup>3</sup> This is principally due to the development of an adsorption theory<sup>4</sup> which permits the calculation of the specific surface of any solid for which vapor adsorption data are available. Therefore, it should be possible to establish a body of area data for vapor molecules adsorbed on solid surfaces analogous to the data for insoluble molecules adsorbed on liquid surfaces.

As will be explained in the following section, cross-sectional area data for molecules adsorbed on solid surfaces are subject to restriction in that they are based on specific surface data which, in turn, are based on cross-sectional area data. If the experimental results are properly interrelated, however, it is possible to obtain accurate relative values for molecular cross-sectional areas.

**Theoretical.**—Brunauer, Emmett and Teller<sup>4</sup> have developed an equation in the form

$$q_m = \frac{q(p_0 - p)(p_0 - p + cp)}{cp p_0} \quad (1)$$

$q_m$  = quantity of vapor adsorbed when a monomolecular layer exists, g. per g. of adsorbent.

$q$  = quantity of vapor adsorbed at any pressure, g. per g. of adsorbent.

$p$  = pressure;  $p_0$  = saturation pressure.

$c$  =  $(a_1 b_1 / a_2 b_2) \exp. (E_1 - RT.E_2) /$

$E$  = energy of adsorption.

$a$  and  $b$  are probability factors in the equations:

$ap$  = number of molecules condensing per unit area;

$b \exp. (E/RT)$  = number of molecules evaporating per unit area.

Subscripts "1" refer to first layer of adsorbed molecules.

Subscripts "2" refer to all other layers (average values).

As pointed out in their paper, the equation may be transposed to give

$$p/q(p_0 - p) = 1/cq_m + p(c - 1)/cq_m p_0 \quad (2)$$

Since  $p$  and  $q$  can be measured, this straight-line form of the equation can be used to evaluate  $c$  and

(1a) Original manuscript received October 21, 1943.

(1b) Present address: Jackson Laboratory, E. I. du Pont de Nemours and Co., Deepwater Point, N. J.

(2) Adam, "The Physics and Chemistry of Surfaces," Oxford Press, New York, N. Y., 1941, p. 50.

(3) Brunauer, "The Adsorption of Gases and Vapors. Vol. I. Physical Adsorption," Princeton University Press, Princeton, 1943.

(4) Brunauer, Emmett and Teller, *THIS JOURNAL*, **60**, 309 (1938).

$q_m$ . The specific surface of the adsorbent is given by the equation

$$\Sigma = Nq_m\sigma/M \quad (3)$$

$\Sigma$  = specific surface, sq. cm. per g. of adsorbent.

$N$  = Avogadro number.

$\sigma$  = cross-sectional area of a single molecule (in plane of adsorbent surface), sq. cm.

$M$  = molecular weight.

Therefore if  $\sigma$  is known,  $\Sigma$  can be calculated. Emmett<sup>5</sup> has given a detailed treatment of this method as applied to the low temperature adsorption of nitrogen.

When pressure-area curves are determined for insoluble monolayers spread on water, the area per molecule is obtained from the equation

$$A = MS/WN \quad (4)$$

$A$  = area per molecule, sq. cm.

$W$  = weight of insoluble material spread on surface, g.

$S$  = total area available to monolayer, sq. cm.

In the same manner, the area available to each molecule adsorbed on a solid surface can be calculated from the analogous equation

$$A = M\Sigma/qN \quad (5)$$

With pressure-area data for insoluble monolayers, it is possible to recognize one portion of the curve as corresponding to close-packed chains. The area per molecule in this region is accepted as being equivalent to the actual area of the molecule in a plane parallel to the adsorbing surface, that is, the cross-sectional area (hereafter referred to as "section area"). This section area is found to be approximately equal to that which would be predicted from measurements of molecular dimensions in the normal condensed phases (liquid or solid).

Section area data obtained from pressure-area data for insoluble monolayers are known to vary with the temperature or surface pressure. It would be expected that similar results would be obtained with adsorbed layers on solids, and therefore  $\sigma$ -values used in equation (3) would vary somewhat with temperature, surface pressure, and solid surface.

By use of equation (2), the adsorption corresponding to a complete monolayer can be calculated. The molecular area,  $A$ , at this point is equivalent to the actual cross-sectional area occupied by the molecules measured in a plane parallel to the adsorbing surface. Accordingly, when

(5) Emmett, *Advances in Colloid Sci.*, **1**, 1 (1942).